



2580 SERIES

2.5mm PITCH WIRE TO BOARD CONNECTOR

● Specifications

Current rating: 3A AC,DC

Voltage rating: 250V AC,DC

Temperature range: -25°C to $+85^{\circ}\text{C}$
(including temperature rise)

Contact resistance: Initial value/10m Ω Max.

After environmental testing/20m Ω Max.

Insulation resistance: 1000M Ω MIN.

Withstanding voltage: 800V AC/minute

Applicable wire: AWG#22-28

● Standards



E115256



LR84767

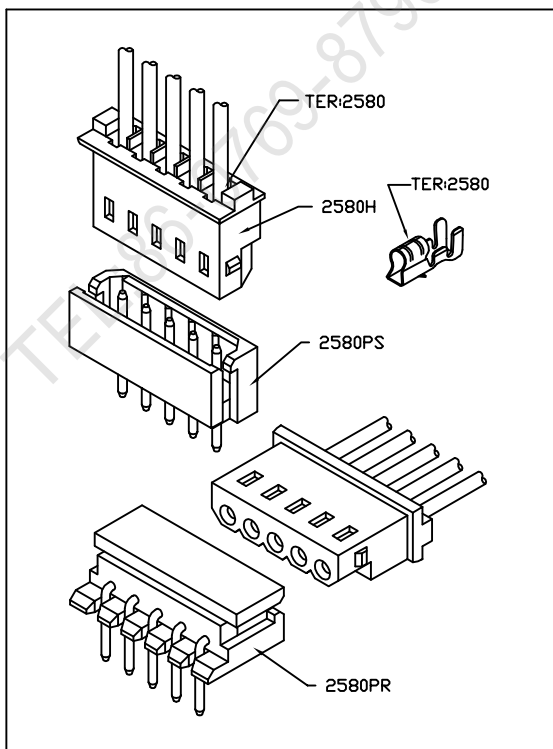

Assembly layout

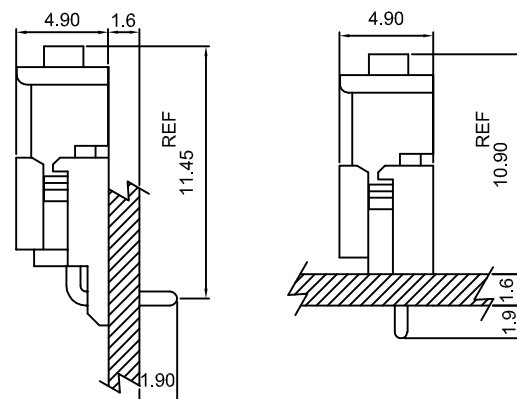



2580H 2.50mm PITCH CRIMP HOUSING

Features:

MAT'L: NYLON 66 UL94V-0
 MATES WITH: 2580 SERIES TERMINAL
 ACCEPTS WITH: 2580PS & 2580PR SERIES WAFER

unit:mm

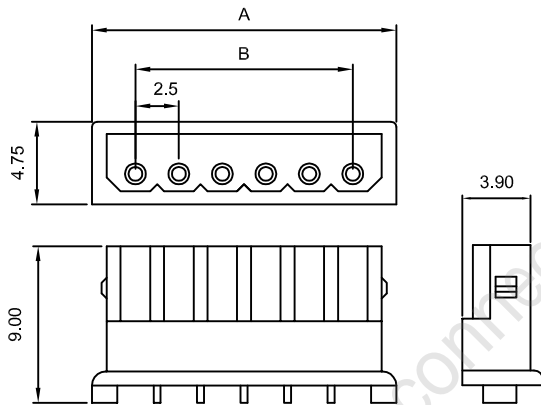

PART NO.	A	B
2580H-02	7.5	2.5
2580H-03	10.0	5.0
2580H-04	12.5	7.5
2580H-05	15.0	10.0
2580H-06	17.5	12.5
2580H-07	20.0	15.0
2580H-08	22.5	17.5
2580H-09	25.0	20.0
2580H-10	27.5	22.5
2580H-11	30.0	25.0
2580H-12	32.5	27.5
2580H-13	35.0	30.0
2580H-14	37.5	32.5
2580H-15	40.0	35.0
2580H-16	42.5	37.5
2580H-17	45.0	40.0
2580H-18	47.5	42.5
2580H-19	50.0	45.0
2580H-20	52.5	47.5

2580 2.50mm PITCH CRIMP TERMINAL

Features:

THICKNESS: 0.2mm
 MA'L: PHOSPHOR BRONZE TIN PLATED
 MATES WITH: 2580H SERIES HOUSING
 ACCEPTS WITH: 2580PS & 2580PR SERIES WAFER
 ACCEPTS WITH ϕ 0.7mm ROUND PIN

unit:mm

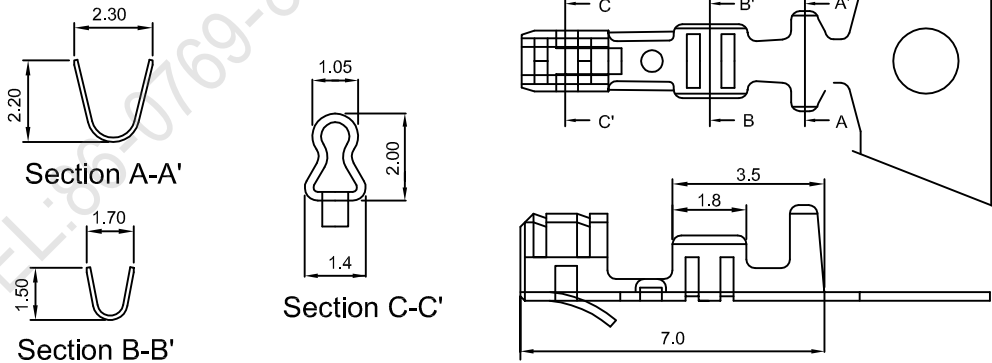

Part No	Wire Range	Insulation O.D.	Material	Finish	Qty/reel
2580-P	AWG #22-#28	ϕ 1.8mm max	Phosphor bronze	Tin-plated	10,000



2580H 2.50mm PITCH CRIMP HOUSING

Features:

MAT'L: NYLON 66 UL94V-0
 MATES WITH: 2580 SERIES TERMINAL
 ACCEPTS WITH: 2580PS & 2580PR SERIES WAFER

unit:mm

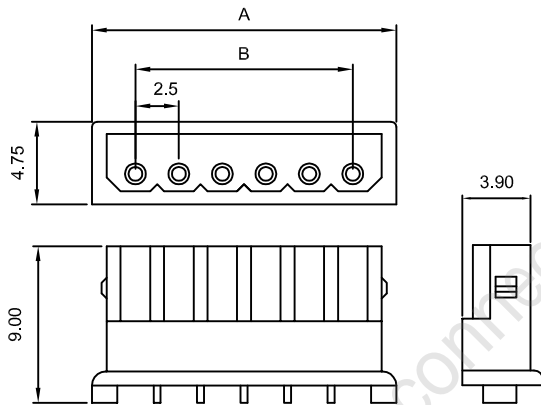

PART NO.	A	B
2580H-02	7.5	2.5
2580H-03	10.0	5.0
2580H-04	12.5	7.5
2580H-05	15.0	10.0
2580H-06	17.5	12.5
2580H-07	20.0	15.0
2580H-08	22.5	17.5
2580H-09	25.0	20.0
2580H-10	27.5	22.5
2580H-11	30.0	25.0
2580H-12	32.5	27.5
2580H-13	35.0	30.0
2580H-14	37.5	32.5
2580H-15	40.0	35.0
2580H-16	42.5	37.5
2580H-17	45.0	40.0
2580H-18	47.5	42.5
2580H-19	50.0	45.0
2580H-20	52.5	47.5

2580 2.50mm PITCH CRIMP TERMINAL

Features:

THICKNESS: 0.2mm
 MA'L: PHOSPHOR BRONZE TIN PLATED
 MATES WITH: 2580H SERIES HOUSING
 ACCEPTS WITH: 2580PS & 2580PR SERIES WAFER
 ACCEPTS WITH ϕ 0.7mm ROUND PIN

unit:mm

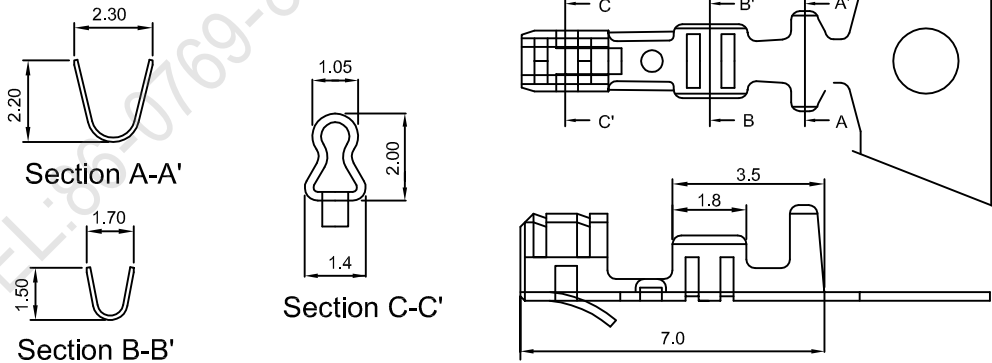

Part No	Wire Range	Insulation O.D.	Material	Finish	Qty/reel
2580-P	AWG #22-#28	ϕ 1.8mm max	Phosphor bronze	Tin-plated	10,000